

# Kinematic Synthesis of a Trailing Six-member Mechanism for Automotive Steering

S. Pramanik<sup>1</sup>

<sup>1</sup>Assistant Professor, College of Military ENGG PUNE, India

santiranjan\_pramanik@rediffmail.com

## Abstract

Kinematic synthesis of a trailing six-member mechanism has been carried out to achieve five precision points of an automotive steering mechanism. The inner wheel can be rotated up to forty five degrees with fair accuracy. Results show that the divergent end behavior of Ackermann Steering Mechanism has been overcome by the present mechanism. The work is similar to earlier work by the present author. But the present mechanism is a trailing mechanism instead of a leading one. This helps to eliminate the spur gears used earlier to bring the mechanism on the rear side of the front axle.

**Keywords:** Kinematic synthesis; steering mechanism; six-member mechanism; steering error.

## 1. Introduction

Fahey and Huston [1] modified a leading Ackermann steering mechanism to an eight-member mechanism in order to eliminate the divergent end behavior of the existing Ackermann steering mechanism. They reduced the steering error to a very low magnitude of 0.03 degree and found out the link sizes of the modified mechanism. However one link is extremely small in size and the wear in the joints and manufacturing inaccuracy will badly affect the performance of the mechanism.

Pramanik [2] considered a central lever steering mechanism having six members. This system had three design parameters and two selected parameters to give five precision points. The precision points were chosen as desired. These precision points gave three non-linear equations with three unknowns. Initial guess of the solution has been made by geometrical method. Using Newton-Raphson method the unknowns were calculated. The structural error had been calculated by subtracting the desired profile from the profile obtained. The structural error fell in between the two errors- one by Fahey eight-member mechanism and the other by Ackermann mechanism.

Simionescu and Smith [3] considered the initial estimate of the design parameters of the same centre-lever mechanism and plotted the design charts which made the work of the design engineer easy. However they neglected the offset between the central adjacent

joints of the central lever common in most practical implementations.

In the present work a trailing centre-lever steering mechanism has been considered to find out the link sizes and the steering error. The inner wheel has been considered to rotate up to forty five degrees and total five precision points have been achieved. This work is different from the previous work of reference [2] in the sense that the previous work was for a leading mechanism and the present work is for a trailing mechanism. The present work eliminates the requirement of four spur gears which have been used earlier to bring the entire mechanism on the rear side of the front axles. Also the divergent end behavior of the error curve has been removed in this work.

In reference [2] the present author considered an offset angle of the central lever in the formulations but kept the value of offset angle as 360 degrees. In the present work this offset angle has been varied from 280 to 360 degrees for the leading mechanism and found out the effect of this on the design parameters.

## Six-Member Mechanism

This is a proposed alternative to an Ackerman Steering Mechanism. In this mechanism (Fig. 1) the equal cranks O1A and O3D are fixed on hinges on the wheel centre line. The intermediate link CBO2 rotates about fixed point O2. The connecting links AB and DC are equal in size. That the mobility of the mechanism is unity can be demonstrated by

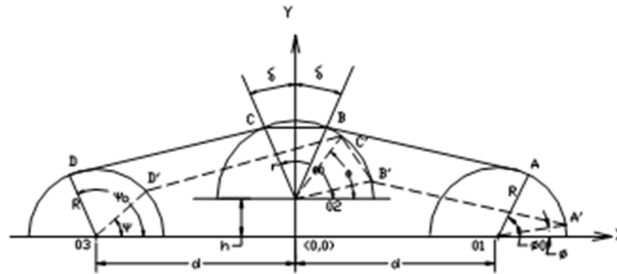

Fig1. Basic Geometry of six-member Mechanism

Inspection or through an application of Gruebler's equation.

Therefore, there will be a constrained motion. When the vehicle moves along a straight path the cranks O1A and O3D make angles  $\phi_0$  and  $\psi_0$  with the x-axis. The angles  $\phi_0$  and  $\psi_0$  are complementary angles, i.e.  $\psi_0 = \pi - \phi_0$

Assuming that  $\delta = \pi$  the Fig. 1 reduced to Fig. 2(d).

In the system shown in Fig. 2 (d) the links 3 and 4 joined at point B, when the vehicle moves along a straight path. For the right turn of the vehicle the two precision points were obtained and two other precision points were found for left turn of the vehicle since the mechanism was assumed to be symmetrical about y-axis for motion along a straight path. The rotation of the link 2 and 5 were transmitted to the steering knuckles through simple gear trains to change the direction of rotation. The mechanism was such that when the link 2 rotated 61 degrees clockwise (seen from the top), the link 5 rotated 40.90301 degrees clockwise, which was required for correct steering with track to wheel base ratio of six tenths. It had been assumed that after 61 degree rotation of the inner wheel, the links 2 and 5 became parallel. It was obvious that the inner wheel rotated larger than the outer wheel while negotiating a turn. Also from the symmetry of the system during straight motion of the vehicle, the links 2 and 5 made complimentary angles with the x-axis. Therefore, the values of  $\phi_0$  and  $\psi_0$  were given by

$$\begin{aligned} \phi_0 &= 90 + (61-40.90301)/2 = 100.048495 \text{ degree} \\ \psi_0 &= 90 - (61-40.90301)/2 = 79.951505 \text{ degree} \\ \alpha &= \phi_0 - 61 = 39.04849 \text{ degree} \end{aligned}$$

Here the law of correct steering is given by the following equation

$\text{Cot}(A_o) - \text{cot}(A_i) = w$ , where  $A_o$  = rotation of outer wheel;  $A_i$  = rotation of inner wheel and  $w$  = ratio of track width to wheelbase.

The three precision points were zero, 34.8 and 61 degrees rotation of the inner wheel. It is also to be noted that links 3 and 4 were collinear and perpendicular to vehicle axis at the precision point

corresponding to 61 degrees of rotation of the inner wheel.

In the coordinate system shown (Fig. 1) the coordinates of different points were as under:

$$\begin{aligned} A &\equiv (d + R \cos \phi_0, R \sin \phi_0) \\ B &\equiv (r \sin \delta, h + r \cos \delta) \\ A' &\equiv (d + R \cos \phi, R \sin \phi) \\ B' &\equiv (r \cos (\theta - 2\delta), h + r \sin (\theta - 2\delta)) \\ C &\equiv (-r \sin \delta, h + r \cos \delta) \\ D &\equiv (-d + R \cos \psi_0, R \sin \psi_0) \\ C' &\equiv (r \cos \theta, h + r \sin \theta) \\ D' &\equiv (-d + R \cos \psi, R \sin \psi) \end{aligned}$$

The length AB and A'B' calculated from the geometry were equated to obtain

$$\begin{aligned} 2(1+K_2 \cos \phi) K_1 \cos(\theta-2\delta) + 2(K_2 \sin \phi - K_3) \\ K_1 \sin(\theta-2\delta) = (1+K_2 \cos \phi)^2 + (K_2 \sin \phi - K_3)^2 - \\ (1+K_2 \cos \phi_0)^2 + 2(1+K_2 \cos \phi_0) K_1 \sin \delta - \\ (K_2 \sin \phi_0 - K_3)^2 + 2(K_2 \sin \phi_0 - K_3) K_1 \cos \delta \end{aligned} \quad \dots(1)$$

where,  $K_1 = r/d$ ;  $K_2 = R/d$  and  $K_3 = h/d$

Equating CD and C'D' the following equation was obtained.

$$\begin{aligned} (K_1 \cos \theta) K_2 \cos \psi + (K_3 + K_1 \sin \theta) K_2 \sin \psi \\ = (K_1 \cos \theta) + K_3 K_1 \sin \theta + K_1 \sin \delta + (1- \\ K_1 \sin \delta) K_2 \cos \psi_0 - K_1 K_3 \cos \delta + (K_3 + K_1 \cos \\ \delta) K_2 \sin \psi_0 \end{aligned} \quad \dots(2)$$

The equations (1) and (2) were rewritten as

$$\begin{aligned} [(1+K_2 \cos \phi) K_1 \cos 2\delta - (K_2 \sin \phi - K_3) K_1 \sin \\ 2\delta] \cos \theta + [(1+K_2 \cos \phi) K_1 \sin 2\delta + (K_2 \sin \phi - \\ K_3) K_1 \cos 2\delta] \sin \theta \\ = K_2 (\cos \phi - \cos \phi_0) - K_2 K_3 (\sin \phi - \sin \phi_0) + \\ (1+K_2 \cos \phi_0) K_1 \sin \delta + (K_2 \sin \phi_0 - K_3) K_1 \cos \delta \end{aligned} \quad \dots(3)$$

and

$$\begin{aligned} (K_2 \cos \psi - 1) K_1 \cos \theta + (K_2 \sin \psi - K_3) K_1 \sin \theta = \\ K_2 \cos \psi - K_2 K_3 \sin \psi + K_1 \sin \delta + (1 - K_1 \sin \\ \delta) K_2 \cos \psi_0 - K_1 K_3 \cos \delta + (K_3 + K_1 \cos \delta) K_2 \sin \\ \psi_0 \end{aligned} \quad (4)$$

Solving for  $\cos \theta$  and  $\sin \theta$  from equations (3) and (4) and using the identity  $\sin^2 \theta + \cos^2 \theta = 1$ , the following equation was obtained.

$$[E(K2 \sin\psi - K3) - F\{(1+K2 \cos \varphi) \sin 2\delta + (K2\sin\varphi - K3) \cos 2\delta\}]^2 + [F\{(1+K2 \cos\varphi) \cos 2\delta - (K2 \sin\varphi - K3) \sin 2\delta\} - E(K2 \cos \psi - 1)]^2 = \{[(1+K2\cos\varphi)\cos 2\delta - (K2\sin\varphi - K3) \sin 2\delta] (K2 \sin \psi - K3)K1 - \{(1+K2 \cos \varphi) \sin 2\delta + (K2\sin \varphi - K3) \cos 2\delta\}(K2 \cos \psi - 1)K1\}^2 \quad (5)$$

Where

$$E = K2(\cos\varphi - \cos\varphi_0) \quad K2K3(\sin\varphi - \sin\varphi_0) \quad + \quad (1+K2\cos\varphi)K1\sin\delta + (K2\sin\varphi - K3) K1\cos \delta$$

and

$$F = -K2\cos\psi - K3K2\sin\psi + K1 \sin\delta + (1-K1\sin\delta) K2\cos\psi_0 - K1K3\cos\delta + (K3+K1\cos\delta) K2\sin\psi_0$$

The accuracy points were denoted by  $(\varphi_i, \psi_i)$  where  $i = 1, 2, 3$ . The equation-5 was satisfied by these accuracy points. This lead to three nonlinear equations with three unknown's viz.  $K1, K2$  and  $K3$ . These unknowns were the design parameters.

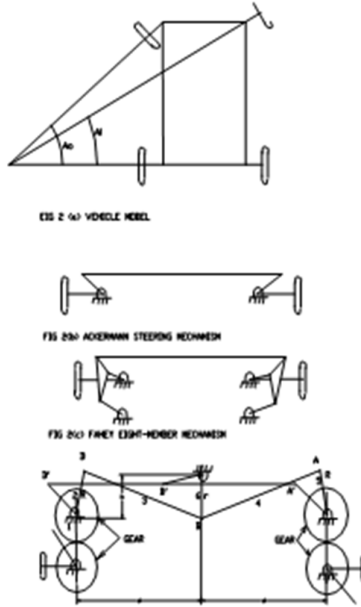

Fig2. (a), Vehicle Model (b) Ackermann Steering Mechanism (c) Fahey Eight Member Mechanism (d) Previous Proposed Mechanism

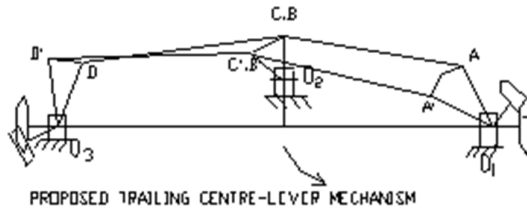

Fig3.. Present Proposed Mechanism

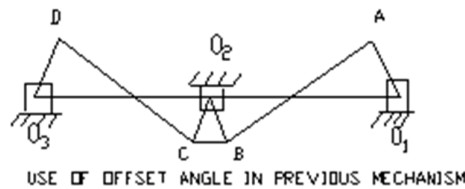

Fig4. Previous Proposed Mechanism With Offset Angle

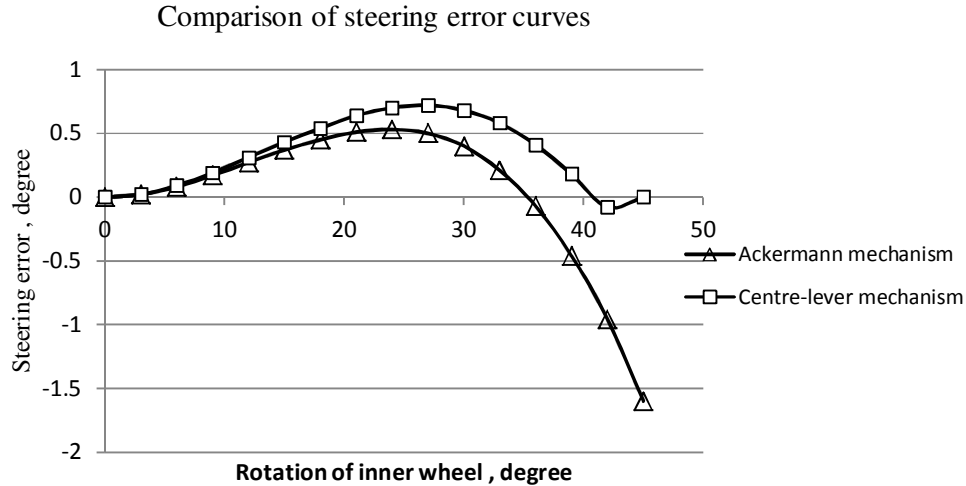

Fig5. Comparison of Steering Error

2. Numerical Analysis

The Newton-Raphson Method had been used to solve the nonlinear equations involving three design parameters. The equation (5) was rewritten as 
$$Y = [E(K2 \sin \psi - K3) - F\{(1+K2 \cos \varphi) \sin 2\delta + (K2 \sin \varphi - K3) \cos 2\delta\}]^2 + [F\{(1+K2 \cos \varphi) \cos 2\delta - (K2 \sin \varphi - K3) \sin 2\delta\} - E(K2 \cos \psi - 1)]^2 - \{[(1+K2 \cos \varphi) \cos 2\delta - (K2 \sin \varphi - K3) \sin 2\delta](K2 \sin \psi - K3)K1 - \{(1+K2 \cos \varphi) \sin 2\delta + (K2 \sin \varphi - K3) \cos 2\delta\}(K2 \cos \psi - 1)K1\}^2 = 0 \tag{6}$$

When  $(\varphi, \psi)$  combination was replaced by  $(\phi_i, \psi_i)$  in the equation (6) then  $y$  was replaced by  $y_i$  where  $i = 1, 2, 3$ . This gave three equations with three unknowns. The function  $y_i$  was written as

$$y_i = y_i(K1, K2, K3) \tag{7}$$

An initial approximation to the root of the system of equations was made by geometrical method. A rough estimation of the value of  $R$  lead to the following initial values for solving the nonlinear equations.

R	= 2.90	K10	= 0.2257
r	= 2.257	K20	= 0.29
h	= 1.972	K30	= 0.1972

Assuming  $K10, K20$  and  $K30$  to be the initial estimate and letting  $\Delta K1, \Delta K2$  and  $\Delta K3$  the

respective corrections the equations (7) were satisfied i.e.

$$\begin{aligned} f1(K10+\Delta K1, K20+\Delta K2, K30+\Delta K3) &= y1 \\ f2(K10+\Delta K1, K20+\Delta K2, K30+\Delta K3) &= y2 \\ f3(K10+\Delta K1, K20+\Delta K2, K30+\Delta K3) &= y3. \end{aligned} \tag{8}$$

Expanding the equation (8) by Taylor's theorem about the initial solution and neglecting the higher order terms the following matrix equation was obtained.

$$\begin{bmatrix} y1 - f1(K10, K20, K30) \\ y2 - f2(K10, K20, K30) \\ y3 - f3(K10, K20, K30) \end{bmatrix} = \begin{bmatrix} \delta f1/\delta K1 & \delta f1/\delta K2 & \delta f1/\delta K3 \\ \delta f2/\delta K1 & \delta f2/\delta K2 & \delta f2/\delta K3 \\ \delta f3/\delta K1 & \delta f3/\delta K2 & \delta f3/\delta K3 \end{bmatrix} \begin{bmatrix} \Delta K1 \\ \Delta K2 \\ \Delta K3 \end{bmatrix}$$

This was written as

$$P = [J] Q$$

$$\text{or } Q = [J]^{-1} P$$

where  $[J]$  was called the Jacobean Matrix,  $Q$  the correction vector and  $P$  the error.

The correction thus obtained was used to update the initial estimate i.e.

$$K10' = K10 + \Delta K1$$

$$K20' = K20 + \Delta K2$$

and so on.

Assuming  $\delta$  as 180 degree and  $\phi_0$  as 100.048495 degree the solution to the non-linear equations (7) was found out.

**Table.1** Result of Previous Mechanism with Different Offset Angles

$\delta$ degree	R unit	r unit	h unit	Maximum error degree
180	2.9	2.4	2.0569	0.139
170	2.9	2.5072	1.1517	0.139
160	2.9	2.5472	0.1758	0.147
150	2.9	2.5138	-0.958	0.169
140	2.9	2.4294	-2.2705	0.201

### 3. Results

In the present work, taking the track to wheel base ratio of six tenth for the trailing mechanism shown in Fig-3, the initial dimensions of various links are chosen after several trials as  $d=10$  unit;  $R=2.1$ ;  $r=1.0886$ ;  $h=1.9$ ;  $\delta=0$  and  $\phi_0=114$  degree. After calculation the final values of the design parameters are  $K1 = 0.10777$ ;  $K2=0.20999$  and  $K3=0.22261$ . Hence the final dimensions are as follows:

$R=2.0999$ ;  $r=1.0777$  and  $h=2.2261$ .

The steering error curve has been shown in Fig-5. The maximum steering error is 0.715 degree. There are three precision points at zero, 41 degree and 45 degree. This error has been compared with the error of an Ackermann steering mechanism of same steering knuckle length. It has been found that the steering error of the suggested mechanism at the extreme end is less than that of the Ackermann mechanism. Also the divergent end behavior of the Ackermann steering has been eliminated in the suggested mechanism.

If in the previous work of reference[2] the value of  $\delta$  has been taken as 170 degrees then the dimensions of the links are  $d=10$ ;  $R=2.9$ ;  $r=2.4252$ ;  $h=1.0688$  unit and  $\phi_0=100.048495$  degrees. The maximum steering error is 0.268 degree and the error curve has total five precision points. It has been observed that the value of  $\delta$  can be reduced up to 140 degrees to obtain satisfactory results. The values of  $\delta$  have been reduced in steps of 10 degrees and the result has been shown in Table-1. It has been found that the 'h' value becomes negative as the offset is increased. In this way the leading mechanisms of reference [2] can be converted into trailing mechanism. The changed mechanism has been shown in Fig-4.

### Conclusion:

The present work utilizes the same Newton-Raphson method used earlier to find the solution of the design parameters. The initial estimate made in the present mechanism is not possible by geometrical approach but by several trials. The suggested new mechanism is better than the earlier proposed one since the mechanism is a trailing one and the gears have been eliminated. The front portion of the front axles is occupied generally by the engine and power trains hence the front portion needs to be kept vacant for the placement of the engine and power trains. The use of different offset angles in the previous mechanism is an alternative to bring the mechanism to the rear side but the steering knuckle remains in the front.

It may be noted that in the present mechanism the second precision point is close to the third one. Attempts has been made to move the second precision point to little more away from the third point but it could not become possible.

### Reference

- [1]. Fahey, S. O'F. and Huston, D.R., 1997, "A Novel Automotive Steering Linkages", ASME Journal of Mechanical Design, Vol 119, pp.481-484
- [2]. Pramanik, S ,2002," Kinematic Synthesis of a Six-Member Mechanism for Automotive Steering", ASME Journal of Mechanical Design, Vol 124, pp. 642-645.
- [3]. Simionescu, P.A. and Smith, M.R. 2002,"Initial Estimates in the Design of Central-Lever Steering Linkages", ASME Journal of Mechanical Design, Vol 124, pp. 646-651.