

MODELING AND OPTIMIZING THE CORROSIVE WEAR OF STEEL BALLS IN BALL GRINDING MILL

A. Azizi^{1,*}, S. Z. Shafaei², M. Noaparast² and M. Karamoozian¹

* azizi.asghar22@yahoo.com

Received: June 2013

Accepted: October 2013

¹ Department of Mining, Petroleum and Geophysics, Shahrood University of Technology, Shahrood, Iran.

² School of Mining Engineering, College of Engineering, University of Tehran, Iran.

Abstract: This paper was aimed to address the modeling and optimization of factors affecting the corrosive wear of low alloy and high carbon chromium steel balls. Response surface methodology, central composite design (CCD) was employed to assess the main and interactive effects of the parameters and also to model and minimize the corrosive wear of the steels. The second-order polynomial regression model was proposed for relationship between the corrosion rates and relevant investigated parameters. Model fitted to results indicated that the linear effects of all of factors, interactive effect of pH and grinding time and the quadratic effects of pH and balls charge weight, were statistically significant in corrosive wear of low alloy steel balls. The significant parameters in the corrosive wear of high carbon chromium steel balls were the linear effects of all factors, the interactions effect of solid concentration, mill speed, mill throughout, grinding time, and the quadratic effects of pH and solid content. Also, the results showed that within the range of parameters studied, the corrosion rate of 78.38 and 40.76 could be obtained for low alloy and high carbon chromium steel balls, respectively.

Keywords: low alloy steel, high carbon chromium steel, corrosive wear, response surface, modeling and optimizing

1. INTRODUCTION

Ball mills are a common grinding device in the mineral processing industries that are applied to reduce the size of particles. Since many decades, steel balls are being used as grinding media in mineral processing operations. A part from energy costs, wear of grinding balls is a significant industrial problem adding further to the cost of production. Total wear of grinding balls is contributed by different forces such as abrasion, erosion, impact and corrosion [1-2]. It is estimated that well over half of the grinding media wear results from corrosion or dissolution from the active nascent metal surfaces continuously being exposed in grinding [1]. The significance of corrosion in grinding media wear also indicates that metal loss in wet type of grinding is about twice as much as of dry type and this difference is accordingly attributed to corrosion effects [3].

Corrosion has been the subject of scientific study for more than 150 years. There are three primary reasons for concern about and the study of corrosion-safety, economics, and conservation. Corrosion is defined as an interaction between a metal and its environment that results in changes

in the properties of the metal. Corrosion is an electrochemical process and involves the operation of what is described as a "corrosion cell" [4]

The ball corrosion is essentially a kind of oxidant-reduction reaction that takes place on its surface. During grinding of copper sulfide ores due to electrical conductivity of the sulphide minerals, intimate contact occurs among the minerals and grinding media, which leads to electron transfer not only between the dissolved ions and mineral surface, but between the sulphide minerals, upon their contact in the solution. Consequently, electrochemical interaction involving grinding media and mineral surface could take place in a mill with active steel ball material undergoing preferential corrosion while the relatively nobler sulfide minerals serving as cathode surface [5-6].

Many factors affect the metal loss in milling operations such as the composition and metallurgical properties of the grinding media, mineral properties (especially mineralogy, hardness and particle size), chemistry of the pulp (particularly solid content and pH), galvanic contact between media and mineral, and mill operating conditions [3, 7-20]. Several studies

were carried out on the influence of these factors in wear of grinding media and subsequently effect of grinding media wear on the mineral flotation, but empirical or mathematical model were not reported for relationship between these factors and corrosion rate of grinding ball in mineral processing. Only, Chen et al (2006) presented the following regression equation (based on coded variables) for total wear rate of high chromium alloy in phosphate grinding mill [16].

$$\text{wear rate} = 156.24 - 50.31 \times A + 24.81 \times B - 14.63 \times C - 23.75 \times D \quad (1)$$

Where A, B, C and D are solution pH, rotation speed (rpm), mill crop load (%) and solid concentration (%), respectively.

Thus, the current work is aimed to develop a practical and effective technique for modeling and minimizing corrosive wear of ball mill grinding media. This research was also carried out on the Sarcheshmeh copper sulfide ore. Sarcheshmeh is a major porphyry copper deposit, which is located in Kerman Province in the southeastern part of Iran. Sarcheshmeh Copper Mine is the largest copper producer in Iran, and one of the major producers in the world market [21].

2. METHODOLOGY

Experimental design is widely used for controlling the effects of parameters in many processes. Its usage decreases the number of experiments, time and material resources. Furthermore, the analysis performed on the results is easily realized and the experimental errors are minimized. Statistical methods measure the effects of change in operating variables and their mutual interactions on the process [22]. Response surface methodology (RSM) is a group of mathematical and statistical techniques based on an efficient experimental strategy that is used for developing, improving, optimizing the processes and modeling and analyzing engineering problems. It also applies to evaluate the relative significance of some affecting factors even in the presence of complex interactions [22-23]. Two important models are commonly used in RSM as follow: i) the first-

degree model,

$$Y = \beta_0 + \sum_{i=1}^k \beta_i x_i + \varepsilon \quad (2)$$

And, ii) the second-degree model,

$$Y = \beta_0 + \sum_{i=1}^k \beta_i x_i + \sum_{1 < i < j}^k \beta_{ij} x_i x_j + \sum_{i=1}^k \beta_{ii} x_i^2 + \varepsilon \quad (3)$$

Where k , β_0 , β_i , x_i , β_{ii} , β_{ij} and ε represent the number of variables, constant term, coefficients of the linear parameters, variables, the coefficients of the quadratic parameter, the coefficients of the interaction parameters and residual associated to the experiments, respectively [24].

The most popular RSM method is the central composite design (CCD) [22-23]. This design consists of the following parts: 1) a full factorial or fractional factorial design; 2) an additional design, often a star design in which experimental points are at a distance from its center; and 3) a central point.

3. EXPERIMENTAL PROCEDURE

3.1. Materials

The required samples were obtained from the ball mills input of Sarcheshmeh copper mine. Samples were crushed in a jaw crusher. The size fraction of -2000 +250 microns was then collected for experiments. Samples were homogenized and sealed in polyethylene bags and then were chemically analyzed which their chemical compositions presented in Table 1.

Low alloy and high carbon chromium steel balls were employed as grinding media, which their chemical compositions listed in Table 2. The diameters of grinding balls used were 0.5, 0.75 and 1 inch, respectively.

Sodium hydroxide was used as pH modifier to maintain the pH at the targeted value during grinding.

For preparing grinding media electrode,

Table 1. Chemical composition of the Sarcheshmeh ore sample (Wt %)

Element	Cu	Fe	Mo	S	SiO ₂	Al ₂ O ₃
Weight, %	0.74	4.34	0.032	3.05	55.07	14.35

Table 2. Chemical compositions of the grinding media

Ball type	Chemical compositions (Weight, %)							
	C	Si	S	P	Mn	Cr	Mo	Cu
High carbon chromium steel (HS)	2.28	0.698	0.049	0	1	13.25	0.177	0.044
Low alloy steel (LS)	0.24 9	0.173	0.024	0.018	0.586	0.019	0.002	0.012

samples of medium were cut into a size of 7 × 7 mm to fill in a Teflon tube. Then a copper wire was connected to the back of the medium with electrically conductive silver epoxy. After that, the sample was mounted in a Teflon tube with the working surface exposed, and the central part of the tube was sealed with non-conductive epoxy resin. The electrodes surface were gently polished with 500 grit silicon carbide paper prior to each test, and cleaned with acetone and double distilled water. After each experiment, the used medium electrodes were repolished and then reused.

3. 2. Grinding

In order to model and optimize the factors influencing the corrosive wear of grinding media in ball mills, a specialized grinding system was designed in R&D of Sarcheshmeh copper Mine. This system involved a specialized ball mill, electrochemical equipments, including, potentiostat/galvanostat coupled with a personal computer for data acquisition and potential control accompanied by a three-electrode system, the gas purging system and meters for monitoring chemical conditions (Eh, pH and DO). This grinding system could also be used to study the electrochemistry of grinding environment. Specifications and schematic representation of specially designed grinding system (ball mill) presented in Table 3 and Figure 1, respectively.

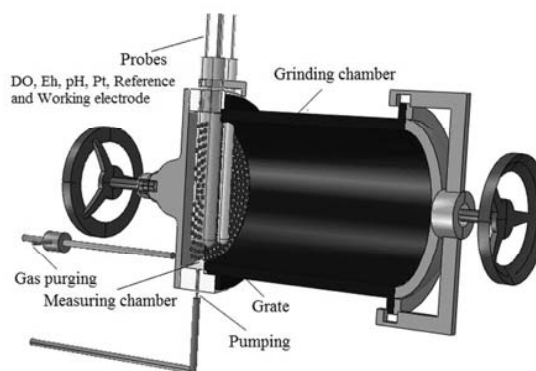

Fig. 1. Schematic representation of specially designed ball mill

Table 3. Specifications of designed ball mill

Mill data	
Material	stainless steel
Grinding chamber	
Diameter inside (mm)	196
Diameter outside (mm)	210
Length (mm)	300
Sampling chamber	
Diameter inside (mm)	212
Diameter outside (mm)	284
Length (mm)	80
Grate	
Thickness (mm)	0.5

3. 3. Experiments

Laboratory tests on the representative samples under different experimental conditions at the selected levels of parameters were conducted, using the specialized ball mill. The samples were ground with low alloy and high chromium steel balls such as 70% of particles were finer than 75µm in diameter. The operating parameters studied were: pH, solid percentage, throughout of grinding circuit, balls charge weight, speed and grinding time.

The response surface methodology (RSM), a central composite experimental design was employed for modeling and optimizing the operational parameters on the balls corrosive wear rate. The selected levels of parameters were shown in Table 4.

$$CR = \frac{0.1288 \times EW \times j_{corr}}{\rho} \tag{4}$$

Where CR is the corrosion rate, jcorr is the corrosion current density (µA/cm²), EW is the equivalent weight of metal (g) and ρ is the density of metal (g/cm³).

Potentiostatic parameters (jcorr and Ecorr) were obtained from the slopes of linear polarization curves (Tafel extrapolation curve). An example of how to measure corrosion rate of media from the polarization curves was presented in Figure 2. Figure 2 indicates that polarization curves (or Tafel extrapolation curve) of low alloy steel (SL) electrode, when 365 g of sample in size 250-2000 microns was ground with 8 kg ball in pH, 10-10.5, solid percentage, 35%, grinding

Table 4. Selected parameters, their coded and real value in center composite design

Factors	Symbol	Low axial Level (-2)	Low factorial Level (-1)	Medium level (0)	High factorial Level (+1)	High axial Level (+2)
pH	A	7	8	9	10	11
Solid content (%)	B	25	30	35	40	45
Throughout (g)	C	180	360	540	720	900
Charge weight (kg)	D	6	8	10	12	14
Speed (rpm)	E	65	70	75	80	85
Grinding time (min)	F	7.5	10	12.5	15	17.5

The balls Corrosion rates were determined using electrochemical equipments including potentiostat/galvanostat (SAMA500 Electrochemical Analysis System, SAMA research center, Iran) and three electrode system linked to the ball mill. The three-electrode system was comprised of an Ag/AgCl (3.0 M KCl) electrode as a reference electrode, Pt wire as the counter electrode and grinding media electrode as working electrode. Measurements were also performed by linear sweep voltammetry technique (Tafel extrapolation method) and then, the corrosion rate was calculated using the following formula [25]:

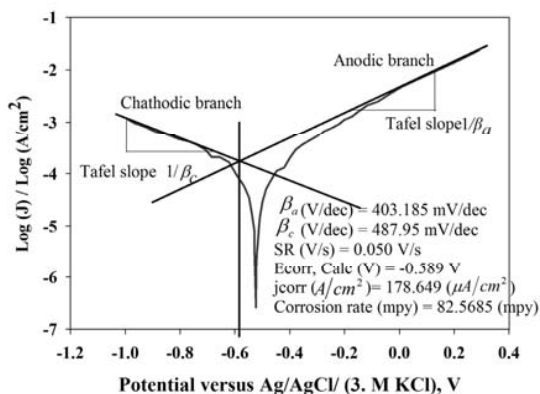

Fig. 2. Tafel extrapolation curve were measured with scan rate, 0.050 (V/s) for low alloy steel media in pH: 10-10.5, solid percentage, 35%, grinding time, 12.5 min, rotation speed, 75 rpm.

time, 12.5 minutes, rotation speed, 75 rpm and non gas purging.

Table 5 shows the calculated corrosion rate for

low alloy and high carbon chromium steel balls, under the various parameter combinations required by the experimental design.

Table 5. A central composite design of experiment to evaluate the effects of operating parameters on the corrosion rate of low alloy (LS) and high carbon chromium steel (HS) balls.

Run	A	B	C	D	E	F	Corrosion rate (mpy) (LS)	Corrosion rate (mpy) (HS)
1	-1	-1	1	1	-1	-1	123.23	76.24
2	1	1	-1	1	1	-1	93.72	56.94
3	1	-1	-1	1	-1	-1	113.43	67.02
4	1	1	-1	1	-1	1	96.94	58.13
5	0	2	0	0	0	0	84.71	48.93
6	0	0	0	-2	0	0	99.68	55.31
7	1	1	-1	-1	-1	-1	78.11	43.14
8	0	-2	0	0	0	0	131.13	96.07
9	1	-1	1	-1	-1	-1	100.88	59.77
10	-1	1	-1	1	1	1	137.47	90.02
11	-1	1	-1	1	-1	-1	100.42	65.52
12	0	0	0	0	-2	0	90.12	54.22
13	1	-1	1	1	-1	1	119.38	70.96
14	1	-1	-1	-1	-1	1	127.59	84.43
15	-1	-1	1	-1	1	-1	128.12	79.83
16	1	1	1	1	-1	-1	89.38	48.57
17	-1	1	1	-1	1	1	125.32	77.09
18	0	0	0	0	2	0	120.48	71.55
19	-1	1	-1	-1	1	-1	107.08	69.66
20	1	1	1	-1	-1	1	91.33	53.01
21	1	1	-1	-1	1	1	105.05	62.03
22	-1	-1	-1	1	1	-1	130.23	73.33
23	-1	1	1	1	1	-1	107.58	64.22
24	0	0	2	0	0	0	96.48	56.04
25	0	0	0	0	0	2	122.95	74.88
26	-1	-1	-1	1	-1	1	141.81	97.38
27	1	1	1	-1	1	-1	92.64	52.18
28	-1	1	1	1	-1	1	122.21	69.47
29	-1	-1	-1	-1	1	1	148.14	103.4
30	1	-1	1	1	1	-1	118.06	68.64
31	0	0	0	0	0	-2	90.79	50.51
32	-1	1	1	-1	-1	-1	97.68	60.18
33	1	-1	-1	1	1	1	126.74	81.67
34	-1	-1	1	1	1	1	139.12	95.32
35	-1	-1	-1	-1	-1	-1	123.54	78.25
36	0	0	0	2	0	0	120.45	70.55
37	0	0	-2	0	0	0	116.39	63.72
38	-1	-1	1	-1	-1	1	129.33	81.45
39	1	1	1	1	1	1	102.76	64.18
40	-1	1	-1	-1	-1	1	116.26	66.89
41	1	-1	-1	-1	1	-1	115.59	61.28
42	2	0	0	0	0	0	88.86	50.04
43	-2	0	0	0	0	0	133.3	94.01
44	1	-1	1	-1	1	1	108.87	69.18
45*	0	0	0	0	0	0	106.04*	64.36*

4. RESULTS AND DISCUSSION

The statistical software package, Design-Expert 7 was used for regression analysis and graphical analysis of the data obtained during the experiments. Analysis of variance (ANOVA) was used to estimate the statistical parameters.

Table 6 shows the results of statistical analysis for selection of model at the 95% confidence level (p -value < 0.05). The lack of fit tests and model summary statistics for the corrosion rate of balls indicated that quadratic model was the best model with p values of 0.1231 and 0.0921,

PRESS of 3623.44 and 3952.49, R- squares of 0.9520 and 0.9327 and Adjusted R-Squares of 0.8932, 0.8501, for low alloy and high carbon chromium steel balls, respectively. The small probability values ($p < .05$) indicate the model validity. Lack of fit is a measure of how well the model fits the data. Strong lack of fit ($p < .05$) is an undesirable property, because it indicates that the model does not fit the data well. It is desirable to have an insignificant lack of fit ($P > 0.1$). furthermore, the predicted residual sum of square (PRESS) indicates how well the model fits the data.

Table 6. The statistical analysis of models

Lack of fit tests for corrosion rate of low alloy steel balls						
Source	Sum of Squares	df	Mean Square	F value	p-value	
Linear	1640.09	38	43.16	3.67	0.0748	
2FI	1092.65	23	47.51	4.03	0.0634	
Quadratic	576.30	17	33.90	2.88	0.1231	Suggested
Cubic	112.61	1	112.61	9.56	0.0271	Aliased
Pure Error	58.88	5	11.78			
Model summary statistics for corrosion rate of low alloy steel balls						
Source	Std. Dev.	R-Squared	Adjusted R-Squared	PRESS		
Linear	6.29	0.8717	0.8538	2290.96		
2FI	6.41	0.9131	0.8478	4351.57		
Quadratic	5.37	0.9520	0.8932	3623.44		Suggested
Cubic	5.35	0.9871	0.8943	9.836E+005		Aliased
Lack of fit tests for corrosion rate of high carbone chromium alloy steel balls						
Source	Sum of Squares	df	Mean Square	F value	p-value	
Linear	1504.66	38	39.60	3.58	0.0680	
2FI	1125.26	23	48.92	4.75	0.0454	
Quadratic	589.39	17	34.67	3.37	0.0921	Suggested
Cubic	68.77	1	68.77	6.68	0.0492	Aliased
Pure Error	51.49	5	10.30			
Model summary statistics for corrosion rate of high carbone chromium alloy steel balls						
Source	Std. Dev.	R-Squared	Adjusted R-Squared	PRESS		
Linear	6.02	0.8365	0.8137	2104.60		
2FI	6.48	0.8764	0.7837	4355.01		
Quadratic	5.40	0.9327	0.8501	3952.49		Suggested
Cubic	4.48	0.9874	0.8968	6.007E+005		Aliased

Analysis of variance calculations was carried out by the response surface method using the quadratic models, which listed in Tables 7 and 8.

Table 7 shows the results of the analysis of variance for the corrosion rate of low alloy steel after removal of insignificant terms. The results show that respectively the linear effects of the solid content (B), pH (A), grinding time (F), the mill speed (E), charge of balls (D) and throughout (C), the quadratic effects of pH () and charge of balls (), and the interaction effect of pH and grinding time (A×F) were statistically significant (at 0.05 level of significance). The proposed regression model including these parameters (in the coded units) is statistically significant:

$$CR = +108.25 - 9.65x_A - 10.57x_B - 2.65x_C + 2.71x_D + 4.39x_E + 7.07x_F - 2.03x_Ax_F + 2.34x_A^2 + 2.09x_D^2 \quad (5)$$

Also, Table 7 shows that the lack of fit of the proposed model (Eq. 5) is not significant, indicating the model can be used adequately to explain the variation in the data. In addition, the coefficients of determination () and adjusted values for model were obtained. R-squared and adjusted R-squared were 0.9055 and 0.8842, respectively. This indicates that the model could explain 90.55% of the variability in response. Also, “Adequate Precision” measures the signal to noise ratio and a ratio greater than 4 is desirable. In this case, a ratio of 25.381 was achieved, indicating an adequate signal and so this model can be used to navigate the design space.

Table 8 indicates the results of the ANOVA for the corrosion rate of high carbon chromium steel after removal of insignificant terms. The results in Table 8 demonstrate that the linear effects of all factors, the interaction effect of the solid

Table 7. Analysis of variance for response surface reduced quadratic model of low alloy steel balls

Source	Sum of Squares	Degree of freedom	Mean Square	F Value	p-value Prob > F	
Model	11991.82	9	1332.425	42.57436	< 0.0001	Significant
A-pH	3723.935	1	3723.935	118.9892	< 0.0001	
B-Solid content	4472.168	1	4472.168	142.8971	< 0.0001	
C-Throughout	281.1651	1	281.1651	8.983938	0.0047	
D-Charge weight	294.252	1	294.252	9.402099	0.0039	
E-Speed	771.6744	1	771.6744	24.65696	< 0.0001	
F-Grinding time	2001.518	1	2001.518	63.95357	< 0.0001	
A*F	131.747	1	131.747	4.209652	0.0468	
A ²	175.6781	1	175.6781	5.613363	0.0227	
D ²	139.6873	1	139.6873	4.463363	0.0409	
Residual	1251.857	40	31.29642			
Lack of Fit	1192.98	35	34.08514	2.894626	0.1183	not significant
Pure Error	58.8766	5	11.77532			
Cor Total	13243.68	49				
Std. Dev.	5.59		R-squared	0.9055		
Mean	111.79		Adjusted R-squared	0.8842		
C.V (%)	5.00		Predicted R-Squared	0.8227		
PRESS	2347.69		Adequate Precision	25.381		

content and the mill speed (B×E) and charge weight and grinding time (C×F) and the quadratic effects of pH (A²) and solid content (B²) are all statistically significant (at 0.05 level of significance). The proposed model for the empirical relationship between the corrosion rate and the important factors (in the coded units) is presented on the basis of the experimental results as follows:

$$\begin{aligned}
 CR = & + 63.90 - 8.38x_A - 8.53x_B - 2.1x_C \\
 & + 1.91x_D + 3.08x_E + 6.21x_F + 1.70x_Bx_E \\
 & - 1.81x_Cx_F + 2.77x_A^2 + 2.89x_B^2
 \end{aligned} \tag{6}$$

The results of model validity reveal that the lack of fit, the value of R², adjusted R² and

Adequate Precision are 0.1824, 0.9110, 0.8881 and 26.094, respectively. These indicates how well the model fitted the data.

Moreover, main effects and interactions plots, which are simulations from Eq. 5 and Eq. 6 as well as Tables 7 and 8, were used for showing the effects of important parameters on the balls corrosion rate as illustrated in Figures 3, 4, 5 and 6.

Figure 3 and 4 exhibit main effects plots for low alloy and high carbon chromium steel balls, respectively.

Figure 5 and 6 indicate interaction effect of pH and grinding time and the interactions of solid content and rotation speed of mill, and throughout and grinding time on low alloy and high carbon chromium steel balls, respectively.

Table 8. Analysis of variance for response surface reduced quadratic model of high carbon chromium steel balls

Source	Sum of Squares	Degree of freedom	Mean Square	F Value	p-value Prob > F	
Model	8672.63	10	867.26	39.9	< 0.0001	significant
A-pH	2806.63	1	2806.63	129.13	< 0.0001	
B-Solid content	2910.44	1	2910.44	133.91	< 0.0001	
C-Throughout	177.07	1	177.07	8.15	0.0069	
D-Charge weight	145.62	1	145.62	6.7	0.0135	
E-Speed	379.58	1	379.58	17.46	0.0002	
F-Grinding time	1544.8	1	1544.8	71.08	< 0.0001	
B*E	92	1	92	4.23	0.0464	
C*F	104.33	1	104.33	4.8	0.0345	
A ²	245.33	1	245.33	11.29	0.0018	
B ²	266.83	1	266.83	12.28	0.0012	
Residual	847.65	39	21.73			
Lack of Fit	796.17	34	23.42	2.27	0.1824	not significant
Pure Error	51.49	5	10.3			
Total	9520.28	49				
Std. Dev.	4.66		R-squared	0.9110		
Mean	68.42		Adjusted R-squared	0.8881		
C.V (%)	6.81		Predicted R-Squared	0.8220		
PRESS	1694.36		Adequate Precision	26.094		

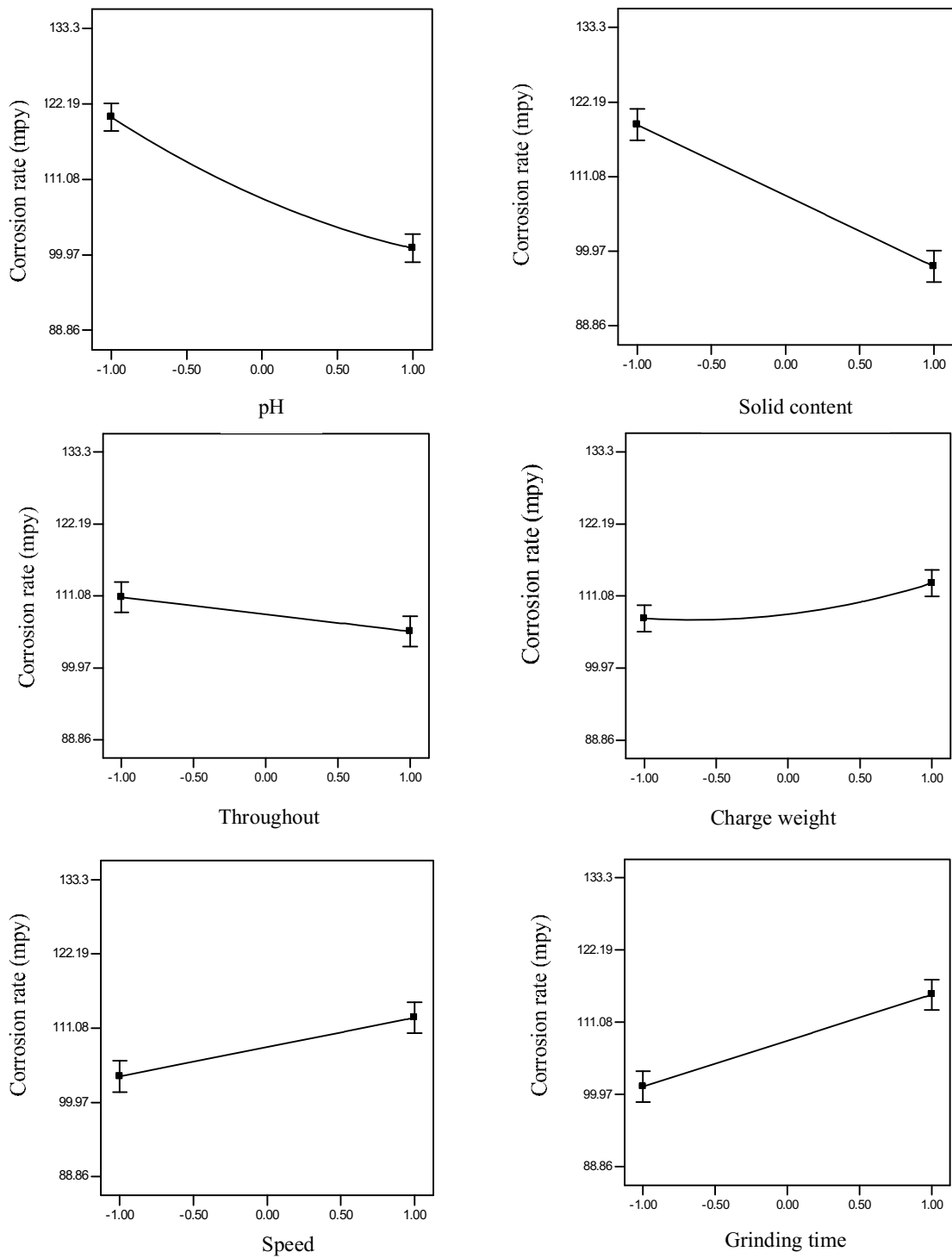

Fig. 3. The effect of main parameters (pH, Solid content, throughout, charge weight, mill speed and grinding time) on the corrosion rate of low alloy steel balls

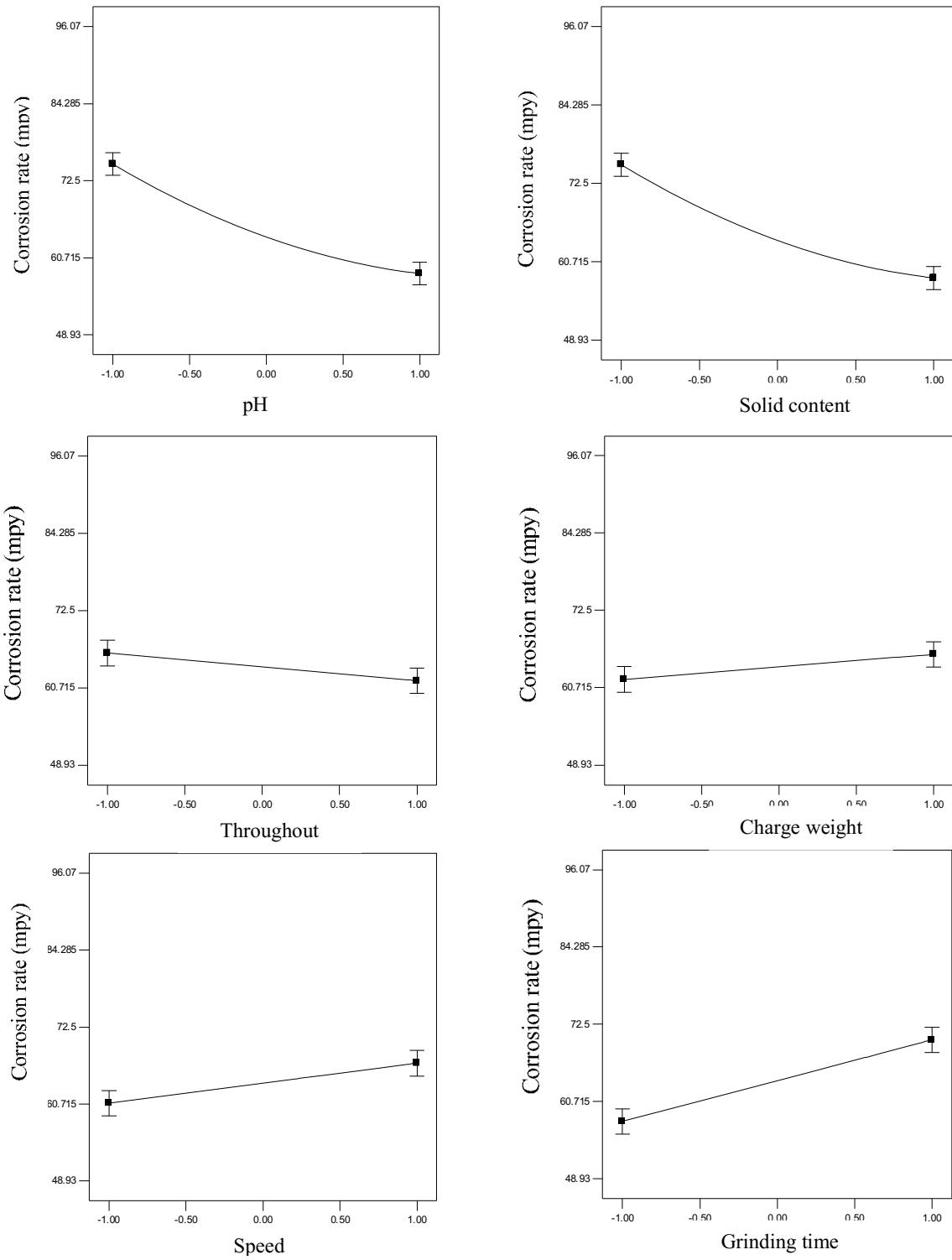

Fig. 4. The effect of main parameters (pH, Solid content, throughout, charge weight, mill speed and grinding time) on the corrosion rate of high carbon chromium steel balls

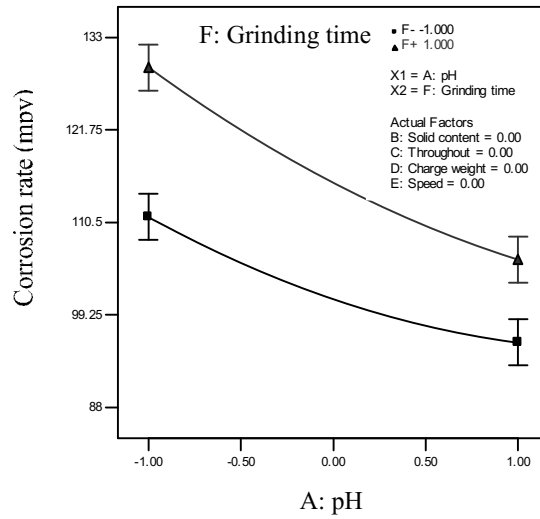

Fig. 5. Interaction effect plot between pH and grinding time for Low alloy steel balls

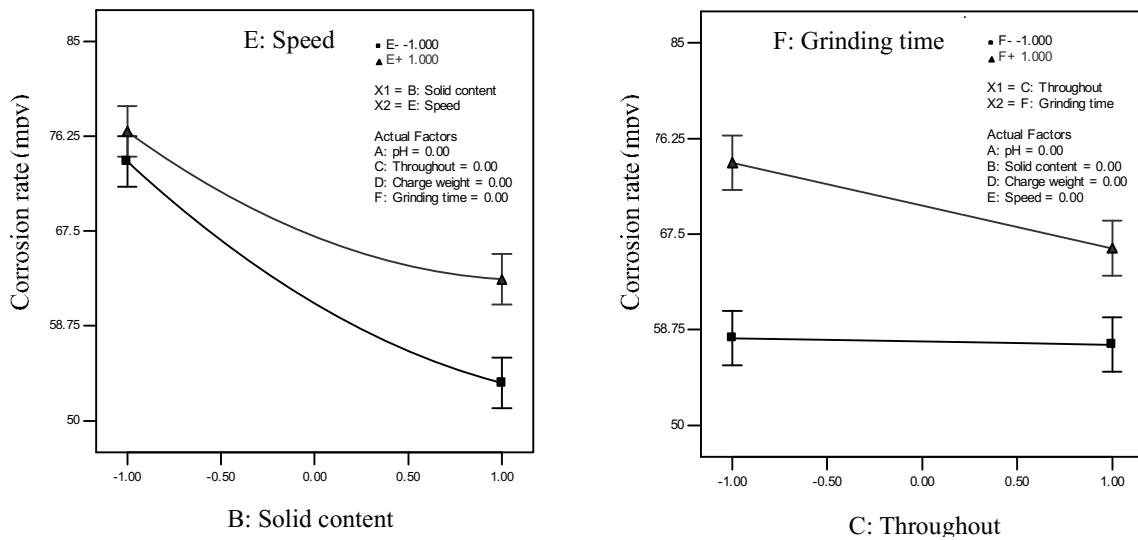

Fig. 6. Interaction effect plot between solid content and mill speed (left) and throughout and grinding time (right) for high carbon chromium steel balls

According to the results of Figures 3-6 and Tables 7-8, the following observations can be made on the effects of the factors in the corrosive wear of balls:

The solid percentage and pH had the most significant on the balls corrosive wear. Increasing the pH (A) and solid percentage in the ranges tested decreased the corrosion rate. This may be

caused by the fact that at lower solid percentage and pH, more oxygen will be dissolved in the pulp, thereby corrosion rate increased while at higher values due to formation the passive ferric oxide film, corrosion rate decreased (Figures 3 and 4).

The calculated corrosion rates imply that the low alloy steel medium oxidizes more quickly

than the high carbon chromium media. High corrosion resistivity of high carbon chromium media (stainless steel) is primarily attributed to the passive oxide film formed on its surface that, exposed to an aqueous solution, is a mixture of iron and chromium oxides, with hydroxide and water-containing compounds located in the outermost region of the film, and chromium oxide enrichment at the metal-film interface [26-28].

As expected, increasing of grinding time enhanced the corrosive wear rate. By increasing the throughout, balls charge and speed the corrosion rate rose. This may be due to reducing the space of motion balls which was decreased at high throughout. Therefore, the contact chance between the balls and the particle diminished thereby corrosion rate reduced.

Factors of pH and charge weight had quadratic effect on corrosive wear of low alloy steel while in corrosive wear of high carbon chromium steel, factors of pH and solid percent had quadratic effect (Figures 3 and 4).

The interaction of pH and grinding time was also significant on the corrosion rate of low alloy steel (Figure 5), showing that increasing grinding time resulted in increasing the corrosion of low alloy steel at lower levels of pH. In addition, the interactions of solid content and rotation speed of mill, and throughout and grinding time were statistically significant on corrosion rate of high carbon chromium steel balls (Figure 6).

4. 1. Optimization of Process Parameters

One of the main aims of this study was to find the optimum process parameters to minimize the medium corrosive wear rate. Numerical optimization using Design Experts software made it possible to find the levels of parameters that minimize the objective function (corrosive wear rate). Table 9 shows the result of this optimization (based on coded and actual values). The average of three laboratory experiments, at the optimized parameter levels, is also shown in Table 9.

5. CONCLUSIONS

The objective of this study was to model and optimize the factors influencing on the corrosive wear of low alloy and high carbon chromium steel balls. Response surface methodology, central composite design (CCD) was employed to assess the main and interactive effects of the parameters and also to minimize the corrosive wear of the grinding balls studied. The results showed that linear effects of solid percent, pH, grinding time, the mill speed, and throughout (C), the quadratic effects of pH and balls charge weight, and the interaction effect of pH and grinding time were statistically significant on the corrosion rate of low alloy steel balls. Also, results showed that the linear effects of all of factors, the interactions effect of solid

Table 9. The proposed levels of parameters to optimize the corrosive wear rate of balls, validating laboratory experiments

Factors	pH	Solid (%)	Throughout (g)	Charge weight (kg)	Speed (rpm)	Grinding time (min)	Corrosion rate (mpy)	Desirability
Model projections (LS ball)	0.78	1	1	-0.38	-0.99	-1	78.38	0.996
	9.8	40	720	9.25	70.05	10		
Model projections (HS ball)	1	0.97	0.88	-1	-1	-0.75	40.76	0.990
	10	39.85	698.4	8	70	10.63		
Model validation (LS ball)	9.5	40	720	9	70	10	77.07	
Model validation (HS ball)	10	40	700	8	70	10.5	41.44	

concentration and speed and throughout and grinding time and the quadratic effects of pH and solid content were significant on the corrosion rate of high carbon chromium steel balls. In addition, regression equations were proposed for empirical relationship among effective factors and objective function (corrosion rate of balls). Both analysis of variance (ANOVA) and coefficient of determination (R^2) showed that the RSM model was appropriate for the optimization and modeling of low and high carbon chromium alloy steel balls.

Moreover, it was found that optimum values of operational parameters for minimum corrosion rate of low alloy steel balls (i.e. 78.4 mpy) could be obtained at pulp pH, 9.8, solid percentage, 40, throughout, 720 g, balls charge weight, 9.25 kg, rotation speed, 70 rpm and grinding time, 10 minutes. Optimum process parameters for minimum corrosion rate of high carbon chromium steel balls (i.e. 40. 8 mpy) were pulp pH, 10, solid percentage, 40, throughout, 700 g, balls charge weight, 8 kg, rotation speed, 70 rpm and grinding time, 10.5 minutes. The optimized values of the parameters were verified with conducting three experiments on samples.

ACKNOWLEDGEMENT

This work was supported by Sarcheshmeh copper mine (Research and development division) funded by National Iranian Copper Industries Company. The authors wish to thank them for supporting this research.

REFERENCES

1. Jang, J. W., Iwasaki, I. and Moore, J. J., "The effect of galvanic interaction between martensite and ferrite in grinding media wear". *Corrosion*, 1989, 45, 402-407.
2. Natarjan, K. A., "Ball wear and its control in the grinding of a lead-zinc sulphide ore". *Int. J. Miner. Process.*, 1992, 34, 161-175.
3. Natarjan, K. A., "Laboratory studies on ball wear in grinding of a chalcopryrite ore". *Int. J. Miner. Process.*, 1996, 46, 205-213.
4. Sarmasti Emami, M. R., "An experimental and theoretical investigation of corrosion mechanism in metallic stack". *IJMSE*, 2012, 9, 58-66.
5. Yelloji Rao, M. K. and Natarjan, K. A., "Factors influencing ball wear and flotation with respect to ore grinding. *Miner*". *Process. Extract. Metall. Rev.*, 1391, 7, 137-173.
6. Hu, Y., Sun, W., Wang, D., "Electrochemistry of Flotation of Sulphide Minerals", Tsinghua University Press: Beijing and Springer-Verlag Berlin Heidelberg, 2009.
7. Iwasaki, I., Riemer, S. C., Orlich, J. N. and Natarjan K. A., "Corrosive and abrasive wear in ore grinding". *Wear*, 1985, 103, 253-267.
8. Moore, J. J., Perez, R., Gangopadhyay, A. and Eggert, J. F., "Factors affecting wear in tumbling mills": influence of composition and microstructure. *Int. J. Miner. Process.*, 1988, 22, 313-343.
9. Yoon, R. H., Pazhianur, R., Adel, G. T. and Richardson, P. E., "Cathodic protection to minimize Corrosive Wear in Ball Mills". *Miner. Metall. Process.*, 1997, 14, 1-7.
10. Chenge, T. W., Simbi, D. J. and Navara, E., "The role of corrosive wear during laboratory milling". *Miner. Eng.*, 2003, 16, 619-624.
11. Peng, Y., Grano, S., Fornasiero, D. and Ralston, J., "Control of grinding conditions in the flotation of chalcopryrite and its separation from pyrite". *Int. J. Miner. Process.*, 2003, 69, 87-100.
12. Peng, Y., Grano, S., Fornasiero, D. and Ralston, J., "Control of grinding conditions in the flotation of galena and its separation from pyrite". *Int. J. Miner. Process.*, 2003, 70, 67-82.
13. Greet, C. J., Small, G. L., Steinier, P. and Grano, S. R., "The Magotteaux Mill®: investigating the effect of grinding media on pulp chemistry and flotation performance". *Miner. Eng.*, 2004, 17, 891-896.
14. Tao, D., Chen, G. L. and Parekh, B. K., "Corrosion protection of mild carbon steel media in phosphate grinding mill using impressed current technology. *Miner. Eng.*, 2005, 18, 481-488.
15. Tao, D., Chen, G. L. and Parekh, B. K., An electrochemical study of corrosive wear of phosphate grinding mill. *J. Appl. Electrochem.*, 2007, 37, 187-194.
16. Chen, G. L., Tao, D., Parekh, B. K., A laboratory study of high chromium alloy wear in phosphate grinding mill. *Int. J. Miner.*

- Process., 2006, 80, 35-42.
17. Huang, G. and Grano, S., Galvanic interaction of grinding media with pyrite and its effect on floatation. *Miner. Eng.*, 2005, 18, 1152–1163.
 18. Huang, G. and Grano, S., Galvanic interaction between grinding media and arsenopyrite and its effect on flotation: Part I. Quantifying galvanic interaction during grinding. *Int. J. Miner. Process.*, 2006, 78, 182-197.
 19. Grano, S., The critical importance of the grinding environment on fine particle recovery in flotation. *Miner. Eng.*, 2009, 22, 386–394.
 20. Brukard, W. J., Sparrow, G. L. and Woodcock, J. T. A review of the effects of the grinding environment on the flotation of copper sulphides. *Int. J. Miner. Process.*, 2011, 100, 1-13.
 21. Barkhordari, H. R., Jorjani, E., Eslami, A. and Noaparast, M., Occurrence mechanism of silicate and aluminosilicate minerals in Sarcheshmeh copper flotation concentrate. *Int. J. Min. Met. Mater.*, 2009, 16, 494-499.
 22. Montgomery, D. C., *Design and Analysis of Experiments*, New York: John Wiley & Sons, 2001.
 23. Myers, R. H., Montgomery, D. C., *Response surface methodology*, New York: John Wiley & Sons, 2002.
 24. Bezera, M. A., Santelli, R. E., Oliveira, E. P., Villar, L. S. and Escaleira, L. A., Review response surface methodology (RSM) as a tool for optimization in analytical chemistry. *Talanta*, 2008, 76, 965-977.
 25. Ailor, W. H., *Handbook of Corrosion Testing and Evaluation*, New York: John Wiley & Sons, 1971.
 26. Moayed, M. H., Deterioration of pitting corrosion of 316 stainless steel by sensitization heat treatment. *IJMSE*, 2005, 2, 9-15.
 27. Pardo, A., Merino, M. C., Coy, A. E., Viejo, F., Arrabal, R. and Matykina E., Pitting corrosion behavior of austenitic stainless steels—combining effects of Mn and Mo additions”. *Corros. Sci.*, 2008, 50, 1796–1806.
 28. Momeni, M., Esfandiari, M. and Moayed M. H., “Improving pitting corrosion of 304 stainless steel by electropolishing technique”. *IJMSE*, 2012, 9, 34-42.